

Telemetry Distribution and Processing For The Second German Spacelab Mission D-2

E. Rabenau Satellite Operational Services GmbH
W. Kruse Deutsche Forschungsanstalt für Luft- und Raumfahrt (DLR)

Abstract

For the second German Spacelab Mission D-2 all activities related to operating, monitoring and controlling the experiments on board the Spacelab were conducted from the German Space Operations Control Center (GSOC) operated by the Deutsche Forschungsanstalt für Luft- und Raumfahrt (DLR) in Oberpfaffenhofen, Germany. The operational requirements imposed new concepts on the transfer of data between Germany and the NASA centers and the processing of data at the GSOC itself. Highlights were the upgrade of the Spacelab Data Processing Facility (SLDPF) to real time data processing, the introduction of packet telemetry and the development of the high-rate data handling front end, data processing and display systems at GSOC. For the first time, a robot on board the Spacelab was to be controlled from the ground in a closed loop environment. A dedicated forward channel was implemented to transfer the robot manipulation commands originating from the robotics experiment ground station to the Spacelab via the Orbiter's text and graphics system interface. The capability to perform telepresence from an external user center was implemented. All interfaces proved successful during the course of the D-2 mission and are described in detail in this paper.

INTRODUCTION

D-2 was launched on April 26, 1993. It successfully accomplished the mission goal

Acronyms

CCSDS	Consultive Committee for Space Data Systems
CAP	Command Acceptance Patterns
CDF	Command Data File
CMD	Command
DLR	Deutsche Forschungsanstalt für Luft- und Raumfahrt
DPS	Data Processing System
DTS	Data Transfer System
ECIO	Experiment Computer Input/Output
EGSE	Experiment Ground Support Equipment
GSFC	Goddard Space Flight Center
GSOC	German Space Operations Control Center
HDRR	High Data Rate Recorder
HRFL	High Rate Forward Link
HRM	High Rate Multiplexer
JSC	Johnson Space Center
KUSP	Ku-Band Signal Processor
LAN	Local Area Network
OD	Operational Downlink
PCM	Pulse Code Modulation
PPF	Payload Parameter Frame
SCIO	Subsystem Computer Input/Output
SIPS	Spacelab Input Processing System
SLDPF	Spacelab Data Processing Facility
SPARCS	Spacelab Realtime Packet Converter System
STL	Subtimeline
TAGS	Text and Graphics System
TDM	Time Division Multiplexer
WAN	Wide Area Network

after 10 days in space. To meet the mission objectives the D-2 mission management required the control center to handle all experiment related data, voice, video and other communication services which resulted in the following requirements:

- (1) Transfer the complete Spacelab high rate telemetry to GSOC. Capture, store and distribute the data.
- (2) Process the Spacelab Experiment Computer and Subsystem Computer Input/Output (ECIO/SCIO) as part of the high rate telemetry and make it available for "quick-look" display to allow the mission operations support team to monitor the progress of the mission, status and health of the experiment computer and facilities.
- (3) Transfer, capture, process and display the Payload Parameter Frame (PPF) telemetry. The PPF consisted of 151 data words of the Spacelab operational downlink processed by the Johnson Space Center (JSC).
- (4) Forward command data blocks originating from the GSOC Command System in order to remotely manipulate the Spacelab and experiment computers.
- (5) Receive and distribute command acceptance and trajectory data blocks.
- (6) Support robot experiment operations by forwarding manipulation commands with minimum delay.
- (7) Support telescience operations from the Microgravity User Center in Cologne, Germany.
- (8) Support the retrieval of data in chronological order from the data archive in order to facilitate troubleshooting and detailed evaluation of the progress of the experiment.
- (9) The performance pertaining to the distribution, processing and display of

telemetry data was required to maintain the original data rates which were in the order of one update/repetition per second for most data channels.

- (10) Deliver the experiment-related high rate Spacelab telemetry to processing equipment provided by the experimenters. The computers installed and operated by the experimenters are hereafter referred to as Electrical Ground Support Equipment (EGSE)
- (11) Offer services prior to the actual mission during the Spacelab integration phase and the "integrated" simulations. Interfaces were implemented to support data flow from the Spacelab integration facility and the Spacelab Training Assembly, both located in Northern Germany. These interfaces, along with the voice, video, fax and other communication services necessary for the overall operations, are not discussed in this paper.

TRANSFER OF TELEMETRY DATA

The concept of the transfer of data as implemented from the requirements is pictured in Figure 1. It distinguishes between the high-rate data generated on board Spacelab and other mission support data transferred in NASCOM block data format.

Spacelab High Rate Telemetry

The Spacelab provided a high-rate data system for the transfer of the ECIO, SCIO and PCM-data generated by the experiment facilities. The ECIO and SCIO contained housekeeping, monitoring and low-rate science data. The experiment channels exclusively contained science data. 5

experiment data and the 2 computer output channels with an overall bitrate of 607.39 kbps were processed by the High Rate Multiplexer (HRM) and nominally down linked at 1 Mbps via the Ku-band signal processor (KUSP). During Ku-band loss of signal the data was recorded onto the High Data Rate Recorder (HDRR) from where it was regularly dumped at a rate of 24:1.

The composite HRM signal was captured, processed and transferred to the GSOC by the Data Transfer System (DTS) implemented at the Spacelab Data Processing Facility (SLDPF), Goddard Space Flight Center (GSFC). The DTS incorporated the enhanced Spacelab Input Processing System (SIPS) and the newly developed Spacelab Realtime Packet Converter System (SPARCS).

The DTS consisted of a triple redundant system that provided real time processing and performed the following tasks:

- (1) Captured the composite HRM onto tapes and monitored its data quality
- (2) Extracted 7 HRM data, the HDRR dump, voice and time channels and monitored their quality
- (3) Captured the extracted HDRR dump on tapes and played back the data at the nominal data rate upon request in parallel to the real-time data transmissions
- (4) Processed the HRM data by the SIPS which output data records containing a number of HRM minor frames for each data channel
- (5) Packetized the data records into Transfer Frames according to CCSDS

recommendations by the SPARCS and output the frames at a rate of 1024 kbps

- (6) Replayed data from the tapes upon request in parallel to the real-time data transmissions.

All minor frames of the HRM data, output by the SLDPF, were frame synchronized and tagged with Spacelab time and downlink quality.

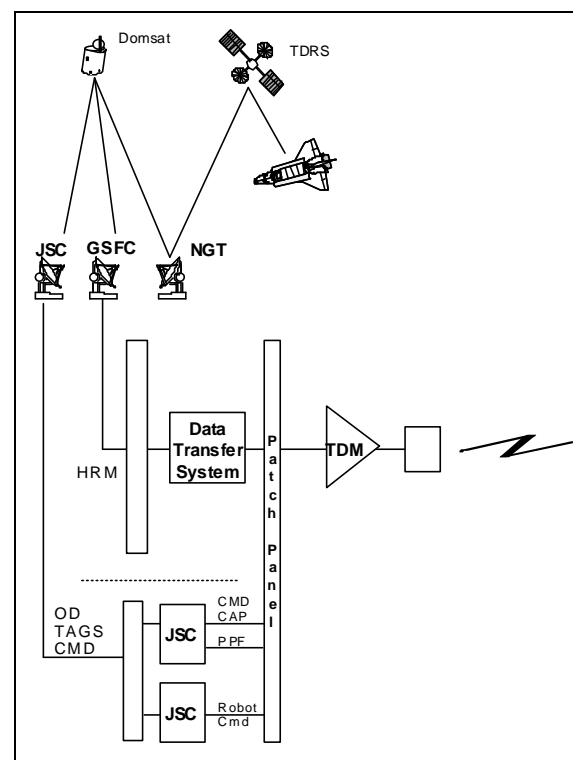

Figure 1 Telemetry Data Flow Schematic

Auxiliary Data

Auxiliary data to support the mission was exchanged between the Johnson Space Center (JSC) and the GSOC. This included the PPF data set which was downlinked as part of the Orbiter Downlink data stream using either channel 1 of the KUSP or S-band propagation, processed and output by JSC at the rate of 1 block per second.

Command data blocks generated by the GSOC command system were forwarded to JSC at the maximum rate of 1 command data block per 3 seconds.

The robot experiment remote manipulation commands which were generated by the robot ground station were forwarded by GSOC to JSC using a dedicated link (HRFL). A new interface was implemented at JSC to validate and merge the commands into the Text and Graphic System channel (TAGS) for high speed uplink.

JSC periodically output trajectory messages (TRAJ) and generated acceptance data blocks (CAP) in response to the GSOC commands.

Time Division Multiplexers and Satellite Links

A triple redundant Time Division Multiplexer (TDM) system was set up both at GSFC and GSOC and provided the gateway to the communication links across the Atlantic. The TDM operated at an aggregate rate of 2048 kbps and incorporated 3 data, 22 voice, 2 FAX and 1 WAN channel. Two diverse satellite paths via two different Intelsat satellites transported the TDM aggregate. Ground stations were installed at GSFC and GSOC. Nominally one satellite link was dedicated for real-time data transfer and the other for the transfer of playback and replay data.

TELEMETRY DATA PROCESSING

The GSOC handled the D-2 telemetry data by its front end, data processing and display systems and communicated with EGSEs provided by the experimenters. Figure 2 shows the GSOC systems in a high-level functional block diagram focusing on the

interconnections between the systems. Figure 3 depicts the functional flow of data and the user interfaces.

Front End Processing System

All incoming and outgoing telemetry data were transported to and from the GSOC Front End System via the Time Division Multiplexer system (refer to Figures 1/ 2).

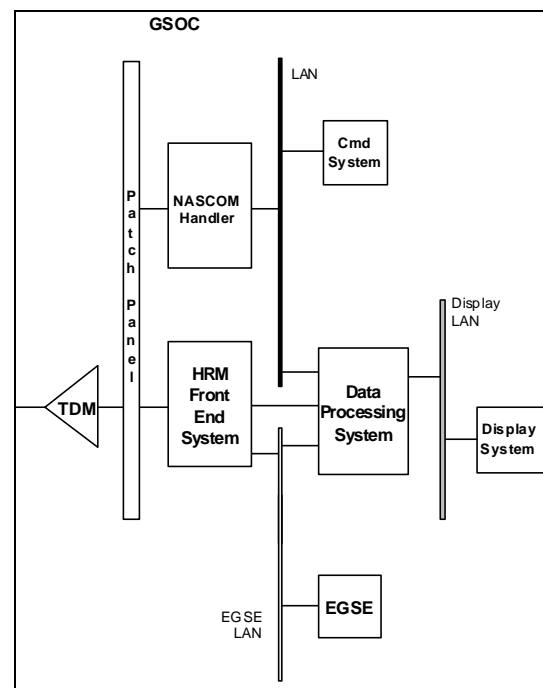

Figure 2 GSOC Functional Block Diagram

- (1) Redundant APTEC[®] high speed input/output processors were implemented to process the Transfer Frames and embedded data. Nominally the APTEC[®] real time and hot backup systems were operated in parallel. In detail the high-rate front end system performed the following tasks.
 - (a) Two frame synchronizers received the Transfer Frames from two different satellite links in parallel

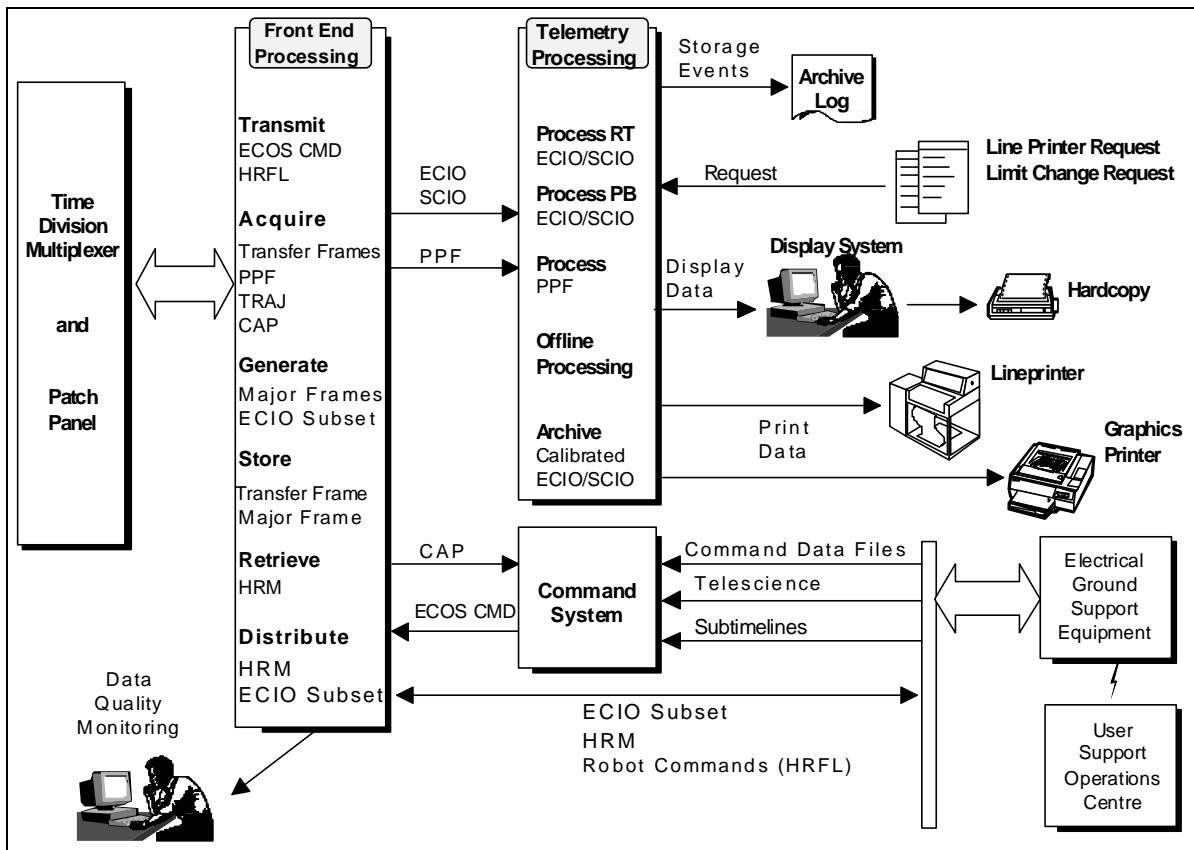

Figure 3 D-2 GSOC Data Processing User Interfaces

- at 1024 kbps each and forwarded both data streams to the processor which performed all operations in parallel.
- (b) The 5 HRM data channels were restored from the Transfer Frames and synchronized on major-frame level (optional).
 - (c) Quality monitor information of the Transfer Frames and the embedded Spacelab minor frames was generated and displayed for on-line evaluation.
 - (d) Subsets from the ECIO and SCIO were generated and transferred to the Data Processing System via a special backplane interface at the rate of 80 kbps.
 - (e) HRM data frames and ECIO subsets were packaged into standard GSOC network record blocks providing time-tags and data quality information and transferred to the EGSEs via a dedicated LAN at the rate of 550 kbps.
 - (f) All Transfer Frames containing payload data and the restored HRM data frames were stored in the high-rate data archive which was based on a video tape storage device. Major-frame data could be

retrieved from the archive and transferred to the EGSE. After the mission the high-rate data archive was reduced by building data records arranged in chronological order and made available on different media for post-mission evaluation by the experimenters.

- (2) A set of redundant processors was implemented to handle all incoming and outgoing auxiliary data in NASCOM block-format via two 19.2 kbps lines. The NASCOM line handlers
 - (a) demultiplexed the NASCOM data blocks and routed the PPF, command acceptance and trajectory data blocks to the DPS, the Command System and the Orbit/Big Screen System respectively
 - (b) monitored the data quality using the established GSOC NASCOM block monitoring
 - (c) received commands from the Command System (ECOS CMD) and the robot EGSE (HRFL) and routed the data to the respective TDM channel.

Data Processing System (DPS)

The Data Processing System was designed to process the Spacelab computer input/output channel data and the Payload Parameter Frame data sets as received from the front end system. For that purpose VAX 6320 processors were operated in a cluster environment. High-speed line printers and laser printers were available to generate computer printouts.

About 3200 parameters were computed as standard Spacelab data types, e.g. engineering unit, character, string and time conversion and up to 4th order polynomial calculations. About 600 parameters were derived from the standard data types and required special processing. These included complex shuttle attitude calculations, ring buffer rearrangements and value sensitive calculations. The software further flagged the out-of-limit conditions of selected parameters and allowed for the change of the out-of-limit values on-line. The computed telemetry was distributed to the display processing system over a dedicated local area network (LAN) using a "broadcast" data transfer method. The total amount of telemetry parameters to be transferred was in the order of 4000 including system parameters.

Telemetry data was stored within the data processing system computers. The storage contained the converted and calibrated telemetry parameters for both real time and playback transmissions in chronological order. The contents of the storage were made available as computer printouts to the experimenters and mission operations support personnel on request.

Display Processing System

At the tail end of the processing chain the telemetry output by the DPS could be observed on "quick-look" displays incorporated in a display processing system. The system consisted of 60 independent computer workstations picking up the "broadcast" parameters from the dedicated LAN. In this configuration each workstation was independent and did not influence the network or other workstations in case of failure.

Each workstation comprised a 19" color monitor, an ink-jet printer, a keyboard and a mouse. Provisions were made for attaching a second monitor. Data was presented as display pages in windows on the display workstation screen. Pages were selected from the display page directory. Graphics and alphanumeric representations and limit violation color coding were supported. The contents of each display page could be printed on the attached printer. The printer supported color printouts. The mouse provided all user interface functions, such as format selection, window manipulation and print initiation. Additionally an auxiliary timing unit allowed the setting of alarms in GMT and MET.

EGSE Services

The control center only distributed the experiment high rate data. Provisions were made for the experimenters to bring in their own computer equipment and plug it into

the network. The requirement for experimenters to operate independent of the control center was supported for the telescience experiment.

The EGSE's ranged from single PC-type computers to whole computer networks. The EGSE's were physically connected to a dedicated LAN, a thick-wire ETHERNET with transceivers as the interface and had to comply to the DECnet protocol standard or the DEC Pathworks standard for DOS/Macintosh. User data connections did not differentiate between inside and outside users. Figure 4 provides an overview of typical EGSE connections to the LAN. Data transfer mechanisms were established for

(a) continuous data, i.e. high-rate telemetry, robot manipulation commands and telescience data, by establishing logical links using the DECnet task-to-task protocol services or non-handshake transfer mechanisms for higher data rates which would

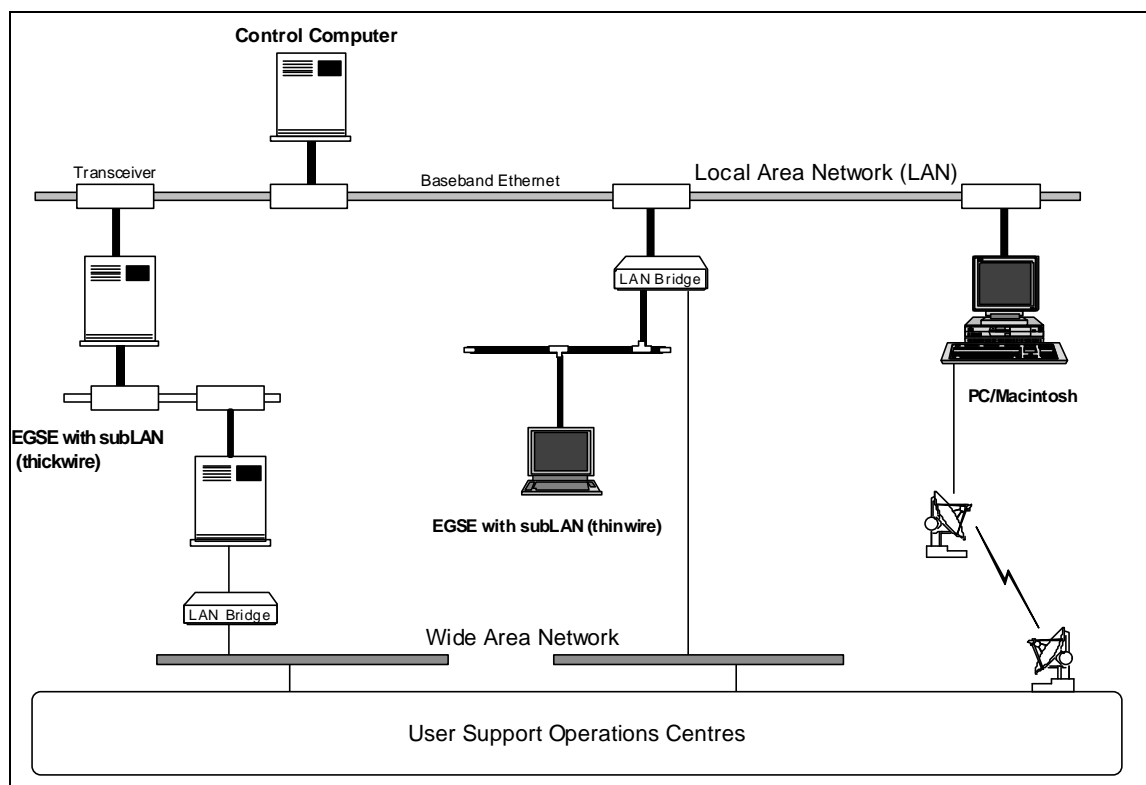

Figure 4 Overview of EGSE Connections to the EGSE LAN

otherwise pose network throughput problems

- (b) non-continuous data, i.e. transfer of experimenter generated Command Data Files (CDF) and ECOS Subtimeline Files (STL), by using the file transfer services provided by the VMS/DECnet/DEC Pathworks operating systems.

High-rate data was distributed to the EGSE in real-time providing the respective data channel was active. Provisions were made to transfer HDRR dump playback data in parallel. The control center also retrieved and replayed data from the high-rate data archive upon request. ECIO subsets were distributed to the EGSE in real-time. There was no option to retrieve and distribute ECIO subsets from the HRM data archive.

Experiment operational support data, such as command data strings (Command Data Files-CDF) and ECOS Subtimeline files (STL) were generated locally by the experimenters and forwarded to the control center's Command System for validation, packaging and transfer. The need for almost instantaneous experimenter interaction in the flow of the experiment further called for the implementation of a telepresence command interface from an external user center to the Command System. The robot manipulation commands generated by the robot ground station fall into the same category. The data was, however, routed directly to the control center's front end at the rate of two NASCOM blocks per second. Special configuration was introduced to cater for the stringent requirements of the robot experiment in respect to data jitter and delay.

STATISTICS SUMMARY

In summary, the GSOC supported the reception and processing of high-rate data from two 1024 kbps lines in parallel, handled data exchange on two 19.2 kbps lines, distributed high-rate data to EGSEs at a rate of 550 kbps, processed about 4000 parameters per second and supported the display of data on 150 display pages. A total of 35 GByte of experiment data was archived (does not include shadowing and overlaps) and made available for post-mission processing.

The data delay times inherent in the data transfer concept from the Spacelab to the control center displays were empirically observed and were about 3.5 s for ECIO and SCIO telemetry, 7 s for PPF telemetry, between 5 and 7 s for the robot experiment closed loop (forward and return link delays).

Conclusion

The success of the D-2 mission validated the concept for transferring high rate data as well as processing and distributing the telemetry at GSOC and effectively operating a Payload Operations Control Center in Europe.